

# ibis Integrated Bindery Systems

## Ibis at Drupa 2012

**NEW  
'PLUS'  
Model**



### New Smart-binder 'PLUS' model features:

- **Higher web speeds:** Web speeds up to 140 m/min (450 feet/min) are now possible with 4-page increments through use of the new 'selective' folder F-200.
- **Higher book production rates:** The machine cycling speed has been increased through the addition of indexing transport belts in the trimmer. This also assists very light 8 or 4 page document production.
- **Enhanced cover feeder:** The feed capacity of the cover feeder has been greatly increased by the addition of an 'auto-load feed hopper'. This also assists feed reliability by reducing weight on the bottom cover in the pile.
- **Auto-stop –stitch:** An automatic stop-stitch system has been to run books out of the machine at the end of a job and to facilitate quick changeover between stitching and gluing.
- **New style guards:** The upper guards have been redesigned to incorporate a more modern curved shape which also makes them lighter, and improves visibility.

### Smart-binder USPs:

- **High speed:** Runs in-line with highest speed web printers (up to 650 feet/min).
- **Flexible:** can be configured to run in-line with the printer, or from a pre-printed roll or off-line from a sheet pile feeder.
- **Good book lay-flat:** Individual sheet folding for optimum book quality.
- **High quality books:** Three side trimming is offered as standard.
- **ISG cold-gluing available** (model SB-3): for stronger bind and book lay-flat.
- **Integrity:** Guaranteed book page integrity for books-of-one, through use of bar-coded sheets and book/sheet tracking. Automatic bad book rejection is included as standard.
- **Cover feeder:** Separate cover feeding available, with optional 'cover-matching' facility.
- **Perfect binding:** May be expanded to model SB-4 or SB-5 to include perfect binding.
- **Options:** A large range of options is available to suit customer special applications.

### New Sprint-binder model 2000 in-line 4-clamp perfect binder:

- **Speed:** up to 1,500 high quality perfect bound books/hour
- **Book thickness and format size changes:** automated
- **Gluing:** Hot melt EVA or PUR available

**NEW**



## IBIS Customized Solutions:

Come and talk with us at Drupa about your requirements! We understand at IBIS that our customers require a **total system solution, not just a machine**. We therefore specialize in providing highly customized solutions, including integrating modules from different suppliers, as needed:

- **Different binding techniques:** saddle-stitching, saddle-gluing, perfect binding, side stitching etc.
- **Different configurations:** in-line, off-line or near line (or a combination of these)
- **Large variety of optional features:** insert sheet feeding, dynamic sheet perforation, card-tipping, hole punching or drilling, spine squaring, additional integrity checking, cameras, loop stitching, centre trimming, waste removal, book stacking, wrapping/strapping, pile loading trolleys, cover driven work-flow, anti-static, optional buffers, modifications for very small or very large books, extra folding, sheet rotation, pile feeding from the side etc.

## Case Study:

### Customized finishing system being installed by IBIS in Rome

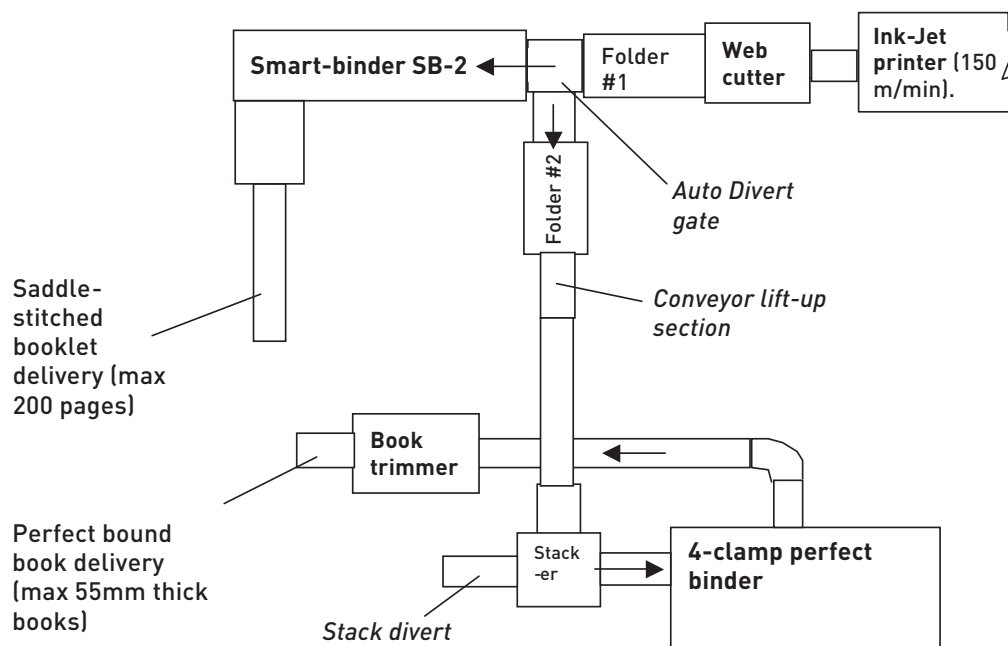

### Key system features:

- 150 m/min printer web speed.
- On-the-run switching between saddle-stitched booklets and perfect bound books.
- Saddle-stitched booklets containing 12 - 200 pages (variable on the run).
- Perfect-bound books from 10 - 55mm (variable on the run).
- Lightweight 60 gsm paper.

### Contact:

IBIS Integrated Bindery Systems Ltd. 9, The Gateway Centre, High Wycombe HP12 3SU, UK.  
Tel +44 1494 561 950 E Mail: Sales@ibis-bindery.com

[www.ibis-bindery.com](http://www.ibis-bindery.com)